

1.

A lift is supported by two steel cables, each of length 10 m and diameter 0.5 cm.

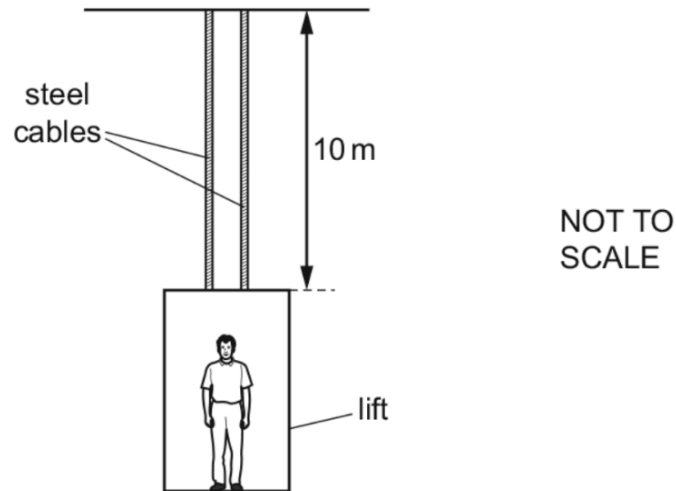

The cables extend by 1 mm when a man of mass 80 kg steps into the lift.

What is the best estimate of the value of the Young modulus of the steel?

- A $2 \times 10^{10} \text{ Nm}^{-2}$
- B $4 \times 10^{10} \text{ Nm}^{-2}$
- C $2 \times 10^{11} \text{ Nm}^{-2}$
- D $4 \times 10^{11} \text{ Nm}^{-2}$

Ans: C

$$\left(\frac{80 \times 9.81}{2 \times \pi \left(\frac{0.5 \times 10^{-2}}{2} \right)^2} \right) \div \left(\frac{10^{-3}}{10} \right)$$

$$= 2 \times 10^{11}$$

remember to consider Area of both, but extension of only 1.

2.

Two wires, P and Q, are made from the same metal and hang vertically from a steel girder.

Wire Q has half the length and twice the diameter of wire P.

Identical masses are attached to the bottom of each wire. Both wires obey Hooke's law as they are stretched by the weight of the masses.

What is the ratio $\frac{\text{extension of wire P}}{\text{extension of wire Q}}$?

A $\frac{8}{1}$

B $\frac{4}{1}$

C $\frac{1}{1}$

D $\frac{1}{2}$

Ans: A

$$E = \frac{FL}{A\alpha} \Rightarrow \alpha = \frac{FL}{AE}$$

$$\text{ratio: } \frac{FL}{\pi r^2 E} \div \frac{F\left(\frac{L}{2}\right)}{\pi (2r^2) E}$$

$$= \frac{FL}{\pi r^2 E} \times \frac{4\pi r^2 E}{\frac{FL}{2}} = \frac{8}{1}$$

3.

A lamp is suspended in equilibrium from a fixed support by three long identical wires.

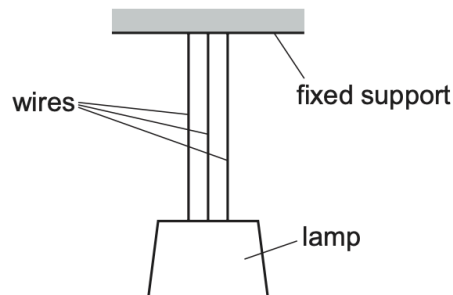

The weight of the lamp causes each wire to have an extension of 0.40 cm. The height h of the lamp above the floor is measured.

The middle wire suddenly breaks and the lamp falls a small distance as the extensions of the remaining two wires increase. The wires obey Hooke's law.

When the lamp is in equilibrium, the height h of the lamp above the floor is measured again.

What is the difference between the two values of h ?

A 0.20 cm

B 0.27 cm

C 0.40 cm

D 0.60 cm

Ans: A

in parallel, $\therefore k_{\text{resultant}} = 3k$

$$x = \frac{W}{3k} = 0.4 \Rightarrow W = 3 \times 0.4k = 1.2k$$

when 1 spring breaks, $k_{\text{resultant}} = 2k$

$$x = \frac{W}{2k} = \frac{1.2k}{2k} = 0.6 \quad \Delta x = \Delta h = 0.6 - 0.4 = 0.2 \text{ m}$$

NOTE:

Stress = F/A

Strain = x/L

E = stress / strain = Fx/AL

4.

A spring of spring constant 30 Nm^{-1} is suspended vertically from its top. The spring obeys Hooke's law. Initially the spring is not compressed and not stretched. A mass of 0.50 kg is attached to the bottom of the spring. The mass is released from rest and falls.

Frictional effects are negligible.

In the motion that follows, what is the maximum extension of the spring?

- A** 0.017 m **B** 0.033 m **C** 0.16 m **D** 0.33 m

Ans: D

- When spring reaches maximum extensions, loss in GPE = gain in EPE
- $mgx = \frac{1}{2} kx^2$
- $0.5 \times 9.81x = 15x^2$
- $4.905x = 15x^2$
- $x = 4.905/15 = 0.327$

NOTE: The maximum extension of the spring occurs when the mass is falling and momentarily comes to rest (at the lowest point of the oscillation). At that instant: The gravitational potential energy (GPE) of the mass is fully converted into the elastic potential energy (EPE) of the spring. The force balance approach ($F = kx$) only works at equilibrium, not at the lowest point where maximum extension occurs!

5.

A wire is stretched by a gradually increasing force. The force–extension graph for the wire is shown.

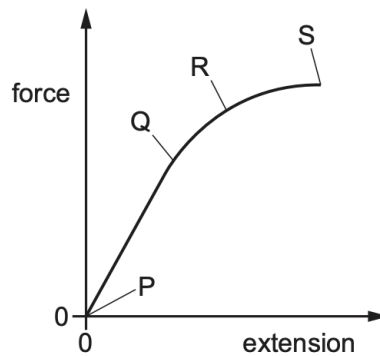

Which statement **must** be correct?



- A Point Q is the elastic limit.
- B Point R is the limit of proportionality.
- C The area under the graph from P to S is the elastic potential energy stored in the wire.
- D The area under the graph from P to S is the work done in stretching the wire.

Ans: D

- Elastic limit is after limit of proportionality

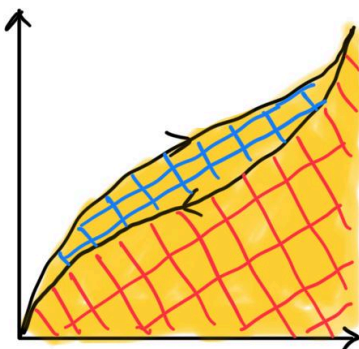
NOTE:



-  work done in stretching
-  elastic potential energy stored
-  thermal energy lost

6.

A wire consists of a 3.0 m length of metal X joined to a 1.0 m length of metal Y.

The cross-sectional area of the wire is uniform.

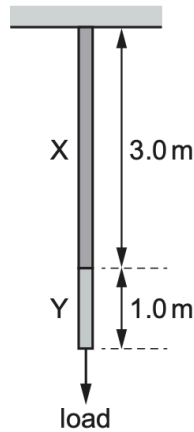

A load hung from the wire causes metal X to extend by 1.5 mm and metal Y to extend by 1.0 mm.

The same load is then hung from a second wire of the same cross-sectional area, consisting of a 1.0 m length of metal X and a 3.0 m length of metal Y.

Both wires are extended within their limit of proportionality.

What is the total extension of this second wire?

- A** 2.5 mm **B** 3.5 mm **C** 4.8 mm **D** 5.0 mm

Ans: B

X	ext	Y	ext
3	1.5	1	1.0
1	0.5	3	3.0
total = 3 + 0.5 = 3.5 mm			

7.

A sample of metal is subjected to a force which increases to a maximum value and then decreases back to zero. A force–extension graph for the sample is shown.

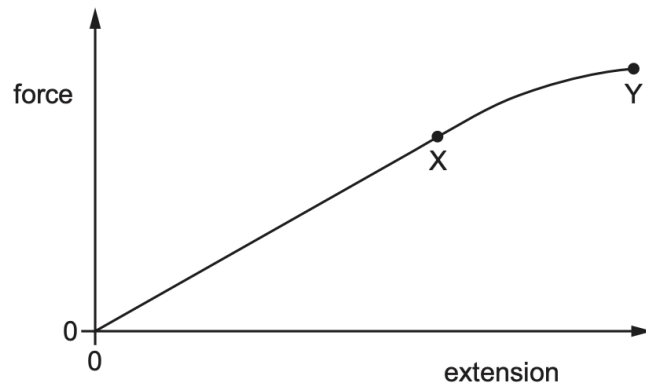

When the sample contracts, it follows the same force–extension curve as when it was being stretched.

What is the behaviour of the metal between X and Y?

- A both elastic and plastic
- B **not** elastic and **not** plastic
- C elastic but **not** plastic
- D plastic but **not** elastic

Ans: C