

1.

Hydrogen and iodine react to form hydrogen iodide in an exothermic reaction. The equation is shown.

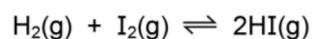

A 1 m^3 reaction vessel contains H_2 , I_2 and HI gases at equilibrium. The temperature is changed such that the total pressure in the 1 m^3 vessel doubles.

What is the effect on the value of K_p and on the position of equilibrium?

	effect on the value of K_p	effect on the position of equilibrium
A	decreases	moves left
B	increases	moves right
C	no change	moves left
D	no change	no change

Ans: A

- Increase in temp favours endothermic
- Thus position of equilibrium shifts left
- Pressure of reactants increase and of product decreases
- $k_p = p(\text{product}) / p(\text{reactant})$

2.

The product of the Contact process is Z.

Which reaction or process leads to the formation of a gas that can neutralise an aqueous solution of Z?

- A** atmospheric lightning
- B** combustion of fuel in an internal combustion engine
- C** the Haber process
- D** thermal decomposition of Group 2 nitrates

Ans: C

- Aqueous solution = H_2SO_4 = acid
- NH_3 gas is basic so neutralises acidic solution

3.

The diagram represents the Haber process for the manufacture of ammonia from nitrogen and hydrogen.

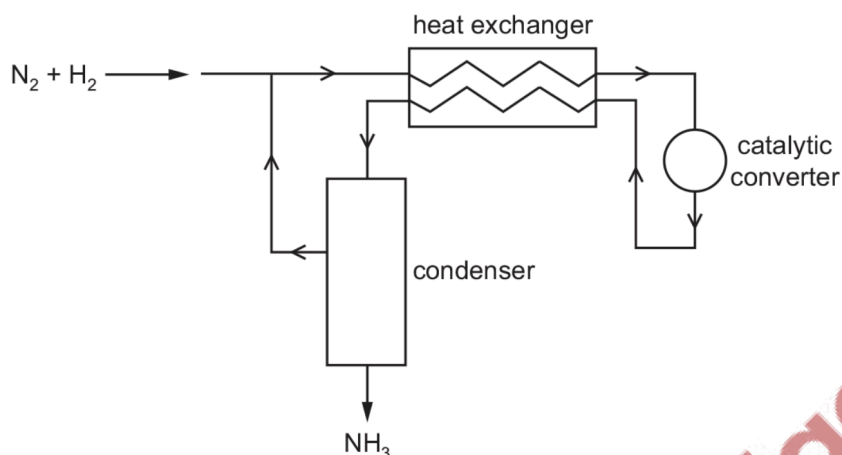

What is the purpose of the heat exchanger?

- A to cool the incoming gas mixture to avoid overheating the catalyst
- B to cool the reaction products and separate the NH_3 from unused N_2 and H_2
- C to warm the incoming gas mixture and shift the equilibrium to give more NH_3
- D to warm the incoming gas mixture and speed up the reaction

Ans: D

- Heat exchanger in Haber process warms incoming gas mixture
- This increases reaction rate

4.

3.60 moles of hydrogen gas and 2.00 moles of iodine vapour are placed in a reaction vessel which is then sealed and maintained at a constant temperature.

The equation for the reaction is shown.

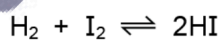

At equilibrium, 3.20 moles of hydrogen remain. All reactants and products are gaseous.

What is the value of K_p under these conditions?

- A 0.0313
- B 0.125
- C 0.156
- D 8.00

Ans: B

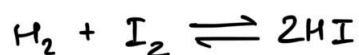

	H_2	I_2	HI
initial	3.6	2.0	0
change	-0.4	-0.4	+0.8
equilib	3.2	1.6	0.8

$$K_p = \frac{(\text{HI})^2}{(\text{H}_2)(\text{I}_2)} = \frac{0.8^2}{3.2 \times 1.6} = 0.125$$

Since all reactants & products are gases, K_p only uses no of moles of reactant and product, to the power of their coefficients.

5.

Nitrogen reacts with hydrogen to produce ammonia.

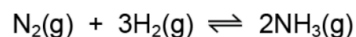

A mixture of 2.00 mol of nitrogen, 6.00 mol of hydrogen and 2.40 mol of ammonia is allowed to reach equilibrium in a sealed vessel of volume 1 dm^3 . It is found that 2.32 mol of nitrogen were present in the equilibrium mixture.

Which expression will give the value of K_c ?

A $\frac{(1.76)^2}{(2.32)(6.96)^3}$

B $\frac{(1.76)^2}{(2.32)(6.32)^3}$

C $\frac{(2.08)^2}{(2.32)(6.32)^3}$

D $\frac{(2.40)^2}{(2.32)(6.00)^3}$

ridge

Ans: A

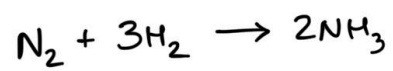

	N_2	H_2	NH_3
initial	2.00	6.00	2.40
change	+ 0.32	+ 0.32 × 3	- 0.32 × 2
equilib	2.32	6.96	1.76

$$K_c = \frac{(1.76)^2}{(2.32)(6.96)^3}$$

6.

10 The equation shows that $\text{H}_2(\text{g})$ and $\text{I}_2(\text{g})$ react to form an equilibrium mixture.

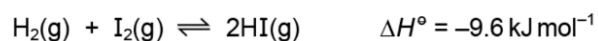

A mixture containing equal amounts of $\text{H}_2(\text{g})$ and $\text{I}_2(\text{g})$ is made at temperature T_1 and the composition of the mixture is monitored. A graph of the results is shown.

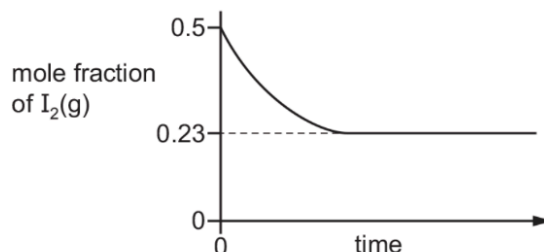

The experiment is repeated at a lower temperature, T_2 .

Which new graph would be obtained?

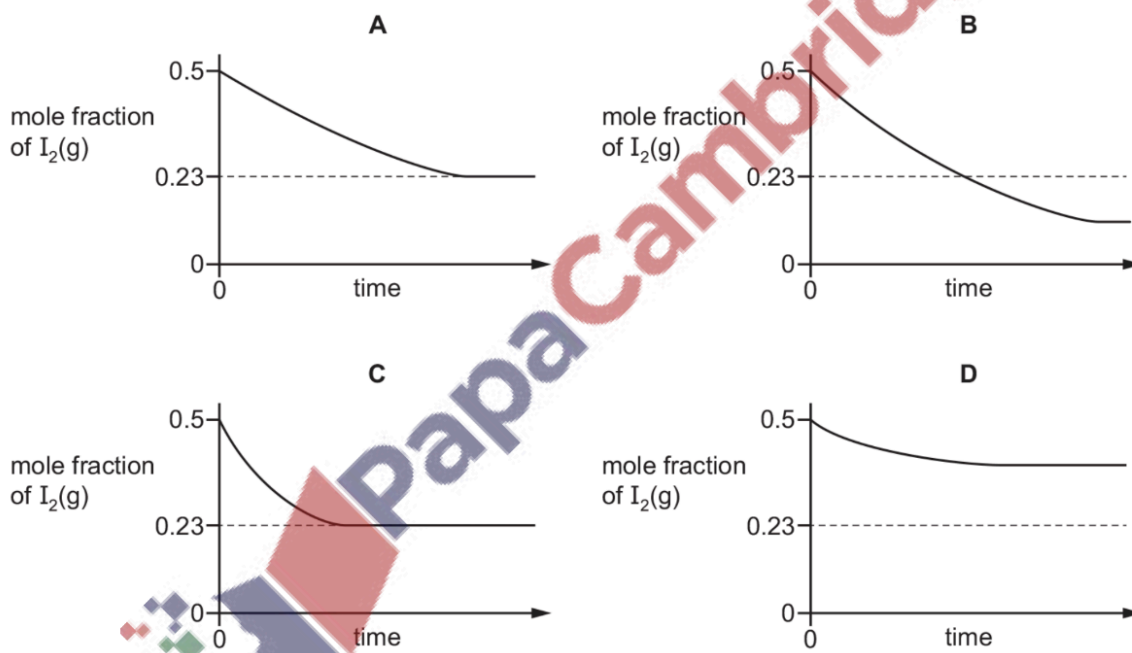

Ans: B

- Exothermic, so lower temperature favours forward reaction
- Equilibrium shifts to right, so concentration of I_2 at equilibrium is lower
- Thus option B! Option D has higher concentration of I_2 !

7.

Two reactions are shown.

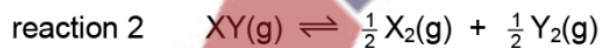
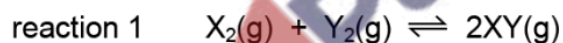

The equilibrium constant, K_p , for reaction 1 is 0.0052.

What is K_p for reaction 2?

- A** 2.6×10^{-3} **B** 13.9 **C** 192.3 **D** 384.6

Ans: B

8.

In aqueous solution, sulfuric acid dissociates as shown.



Analysis of a 2.00 mol dm^{-3} solution of H_2SO_4 found the HSO_4^- concentration to be $1.988 \text{ mol dm}^{-3}$.

What is K_c ?

- A** $1.381 \times 10^5 \text{ dm}^3 \text{ mol}^{-1}$
B $82.34 \text{ dm}^3 \text{ mol}^{-1}$
C $1.214 \times 10^{-2} \text{ mol dm}^{-3}$
D $7.244 \times 10^{-5} \text{ mol dm}^{-3}$

Ans: C

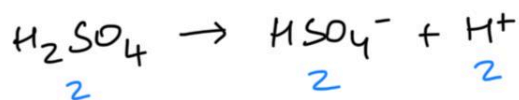

Because reaction goes to completion

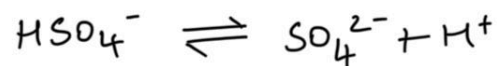

HSO_4^-	SO_4^{2-}	H^+
2	0	2
-0.012	+0.012	+0.012
1.988	0.012	2.012

$$K_c = \frac{(0.012)(2.012)}{1.988}$$

9.

Ammonia is made by the Haber process. The reactants are nitrogen and hydrogen.

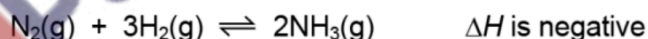

What will increase the rate of the forward reaction?

- A adding argon to the mixture but keeping the total volume constant
- B decreasing the temperature
- C increasing the total pressure by reducing the total volume at constant temperature
- D removing ammonia as it is made but keeping the total volume of the mixture the same

Ans: C

- Adding argon will increase pressure, but partial pressure of N_2 , 3H_2 and 2NH_3 won't be affected, so there is no change in rate of forward reaction.
- Decreasing temperature lowers rate.
- Increasing pressure increases the rate of forward reaction.
- Option D only affects equilibrium position, not rate.

10.

$\text{AgNO}_3(\text{aq})$ is added to a solution of a halide ion, $\text{X}^-(\text{aq})$, and aqueous ammonia is then added.

The ionic equations for the two reactions that occur are shown.

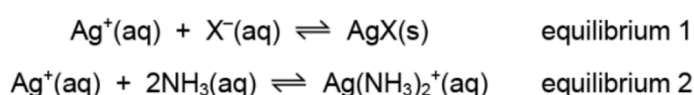

Which statement is correct?

- A The position of equilibrium 1 lies to the left when $\text{X}^- = \text{I}^-$.
- B Increasing the concentration of ammonia causes the position of equilibrium 1 to move to the left.
- C K_c for equilibrium 2 is larger when $\text{X}^- = \text{Cl}^-$ than when $\text{X}^- = \text{I}^-$.
- D Equilibrium 2 is a redox reaction.

Ans: B

- Increasing concentration of ammonia in equilibrium 2 causes decrease in concentration of Ag^+ .
- This will decrease concentration of Ag^+ in equilibrium 1, causing equilibrium position to move left to try and increase concentration of Ag^+ .

11.

Ethyl ethanoate undergoes the following reaction.



Equal amounts of ethanoic acid and ethanol were mixed together and allowed to reach equilibrium.

At equilibrium, the concentrations of both ethanoic acid and ethanol were 0.42 mol dm^{-3} .

What is the concentration of ethyl ethanoate at equilibrium?

- A 0.22 mol dm^{-3}
- B 0.65 mol dm^{-3}
- C 0.81 mol dm^{-3}
- D 1.54 mol dm^{-3}

Ans: C

- Write the reaction in reverse direction, since question states that the ethanoic acid and ethanol were mixed together = reactants
- The value of K_c will now be inverse of 0.27, as the chemical reaction has been reversed.

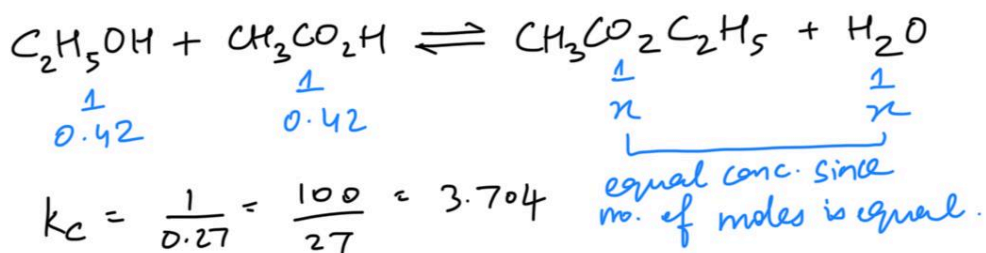

$$K_c = \frac{1}{0.27} = \frac{100}{27} = 3.704$$

$$3.704 = \frac{x \times x}{0.42 \times 0.42} \quad \therefore x = 0.81$$



12.

Two compounds X and Y react to produce compound Z. The reaction is reversible.



When X and Y are mixed together in a closed system a dynamic equilibrium is gradually established.

Which graph could represent the change in the rates of the forward and reverse reactions over time?

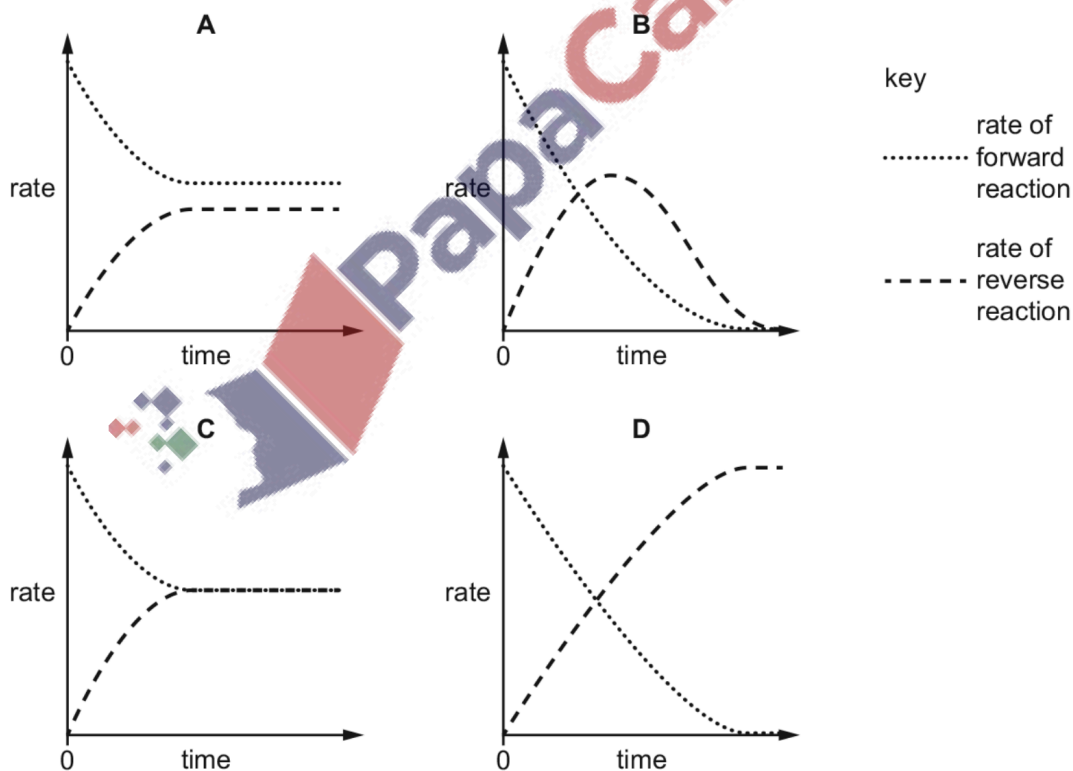

Ans: C

13.

Which oxide is insoluble in aqueous sodium hydroxide?

A MgO

B Al₂O₃

C P₄O₁₀

D SO₂

Ans: A

- MgO = basic oxide so does not react with NaOH (base)
- Al₂O₃ = amphoteric oxide so reacts with NaOH (base)
- P₄O₁₀ and SO₂ = acidic oxide so reacts with NaOH (base)

14.

X, Y and Z are three elements in the third period.

- X reacts with chlorine to give a liquid product.
- Y reacts with chlorine to give a solid product that dissolves in water to give a solution of pH 7.
- Z reacts with chlorine to give a solid product that dissolves in water to give a solution of pH 6.

Which elements are good conductors of electricity?

- A** X and Y **B** Y and Z **C** Y only **D** Z only

Ans: B

- Metals give solid products with chlorine, so X is not a metal
- NaCl dissolves in water to give pH 7
- MgCl₂ dissolves in water and is slightly acidic (pH 6)

15.

The gases X and Y react to form Z.

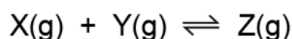

An equilibrium mixture of these three gases is compressed at constant temperature.

What will be the changes in the mole fraction of Z and in K_p ?

	mole fraction of Z	K_p
A	increase	increase
B	increase	no change
C	no change	increase
D	no change	no change

Ans: B

- Pressure increases, so yield of Z increases, so mole fraction of Z increases.
- K_p is only affected by change in temperature; since temperature is constant, there is no change in k_p !

16.

Silver chloride and silver iodide form equilibria when added to water.

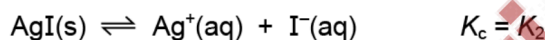
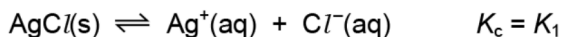

Each equilibrium position lies well to the **left**.

Silver iodide will not dissolve in aqueous ammonia. Silver chloride will dissolve in aqueous ammonia. Another equilibrium is formed.

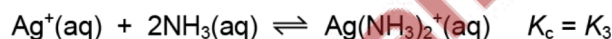

The position of this equilibrium lies to the **right**.

What is the order of magnitude for these three equilibrium constants?

- A $K_1 > K_2 > K_3$
- B $K_2 > K_1 > K_3$
- C $K_3 > K_1 > K_2$
- D $K_3 > K_2 > K_1$

Ans: C

- K_3 is highest since equilibrium position for this is to the right
- $K_1 > K_2$ since AgCl bond is stronger and harder to break and dissociate

17.

In this question you should assume that all gases behave ideally.

Hydrogen and iodine react reversibly in the following reaction. The system reaches dynamic equilibrium.

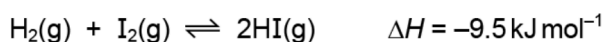

Which statement **must** be true for the K_p of this equilibrium to be constant?

- A The partial pressures of H_2 , I_2 and HI are equal.
- B The external pressure is constant.
- C The forward and reverse reactions have stopped.
- D The temperature is constant.

Ans: D

18.

In this question, all pressures are measured in atm.

The equation represents the equilibrium between three gaseous substances X, Y and Z.



At temperature T_1 , the numerical value of K_p , the equilibrium constant, is 2.

At a higher temperature T_2 , the partial pressures at equilibrium are as shown.

X	Y	Z
2	3	5

Which row is correct?

	the numerical value of K_p at T_2	the forward reaction is
A	54/25	endothermic
B	54/25	exothermic
C	25/54	endothermic
D	25/54	exothermic

Ans: D

- Use formula to calculate K_p
- K_p is decreasing with increasing temperature, which means yield of product decreases, which means backward reaction is favoured with increasing temperature, which means forward reaction is exothermic.

19.

Two moles of compound P were placed in a sealed container. The container was heated and P was partially decomposed to produce Q and R only. A dynamic equilibrium between P, Q and R was established.

At equilibrium x moles of R were present and the total number of moles present was $\left(2 + \frac{x}{2}\right)$.

What is the equation for this reversible reaction?

- A** $P \rightleftharpoons 2Q + R$
- B** $2P \rightleftharpoons 2Q + R$
- C** $2P \rightleftharpoons Q + R$
- D** $2P \rightleftharpoons Q + 2R$

Ans: D

	P	Q	R
	2	0	0
A)	$2-x$	$+2x$	$+x$
B)	$2-2x$	$+2x$	$+x$
C)	$2-2x$	$+x$	$+x$
D)	$2-x$	$\frac{x}{2}$	$+x$

20.

Hydrogen and carbon dioxide gases are mixed at 800 K. A reversible reaction takes place.

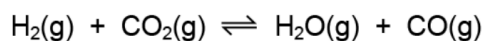

At equilibrium, the partial pressures of H_2 and CO_2 are both 10.0 kPa. K_p is 0.288 at 800 K.

What is the partial pressure of CO in the equilibrium mixture?

- A 5.37 kPa B 18.6 kPa C 28.8 kPa D 347 kPa

Ans: A

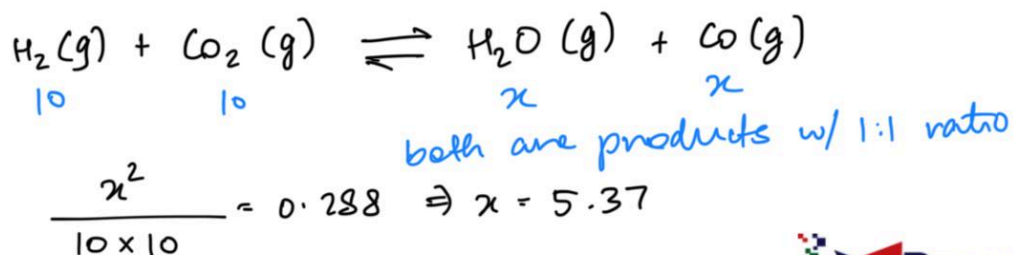

21.

Hydrogen iodide dissociates into hydrogen and iodine.

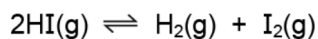

In an experiment, b mol of hydrogen iodide were put into a sealed vessel at pressure p . At equilibrium, x mol of the hydrogen iodide had dissociated.

Which expression for K_p is correct?

- A $\frac{x^2}{(b-x)^2}$ B $\frac{x^2 p^2}{(b-x)^2}$ C $\frac{x^2 p^2}{4b(b-x)}$ D $\frac{x^2}{4(b-x)^2}$

Ans: D

22.

When solid ammonium chloride dissociates at a certain temperature in a 0.500 dm^3 container, ammonia and hydrogen chloride are formed.



The initial amount of ammonium chloride was 1.00 mol , and when the system had reached equilibrium there was 0.300 mol of ammonium chloride.

What is the numerical value of K_c for this reaction under these conditions?

- A 0.490 B 1.63 C 1.96 D 3.27

Ans: C

Solid so doesn't matter

$\text{NH}_4\text{Cl(s)}$	$\text{NH}_3\text{(g)}$	HCl(g)
1	0	0
- 0.7	+ 0.7	+ 0.7
0.3	0.7	0.7

$$\text{conc. of } \text{NH}_3 \text{ \& } \text{HCl} = \frac{0.7}{0.5} = 1.4$$

$$\text{conc. of } \text{NH}_4\text{Cl} = 1$$

$$\therefore K_c = \frac{1.4 \times 1.4}{1} = 1.96$$

- Volume is 0.5 dm^3 NOT 1 dm^3 !! – use this to calculate concentration.
- NH_4Cl is a solid in this case so will have concentration of 1!!

23.

Lithium reacts with nitrogen at room temperature to form solid Li_3N .

Three vessels of equal volume are connected by taps, A and B, as shown.

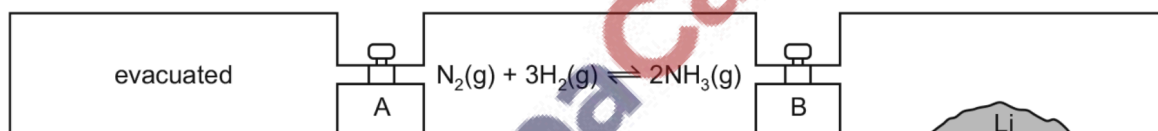

At the start, A and B are closed, the left-hand vessel is evacuated, the middle vessel has the indicated reaction at equilibrium and the right-hand vessel contains lithium only.

Which action would allow the equilibrium mixture to contain the **most** ammonia?

- A Keep both A and B closed.
 B Open both A and B.
 C Open A only.
 D Open B only.

Ans: A

- If B is open, Li reacts with N_2 . This decreases concentration of N_2 , causing position of equilibrium to move to the left to produce more N_2 , decreasing yield of NH_3 .

- If A is open, pressure decreases, causing position of equilibrium to move to the, decreasing yield of NH₃.

24.

A mixture of nitrogen and hydrogen gases, at a temperature of 500 K, was put into an evacuated vessel of volume 6.0 dm³. The vessel was then sealed.



The mixture was allowed to reach equilibrium. It was found that 7.2 mol of N₂ and 12.0 mol of H₂ were present in the equilibrium mixture. The value of the equilibrium constant, K_c , for this equilibrium is 6.0×10^{-2} at 500 K.

What is the concentration of ammonia present in the equilibrium mixture at 500 K?

- A 0.58 mol dm⁻³
- B 0.76 mol dm⁻³
- C 3.5 mol dm⁻³
- D 27 mol dm⁻³

Ans: B

NOTE that the volume is 6dm3 NOT 1!!

25.

Diethylzinc, (C₂H₅)₂Zn, is added to NaOH(aq). Two reactions occur.

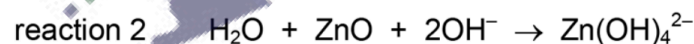
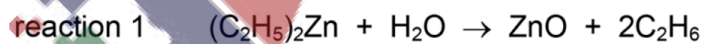

In these reactions, which compounds act as Brønsted–Lowry acids?

	reaction 1	reaction 2
A	(C ₂ H ₅) ₂ Zn	H ₂ O
B	H ₂ O	H ₂ O
C	H ₂ O	ZnO
D	the reaction is not acid / base	ZnO

Ans: B

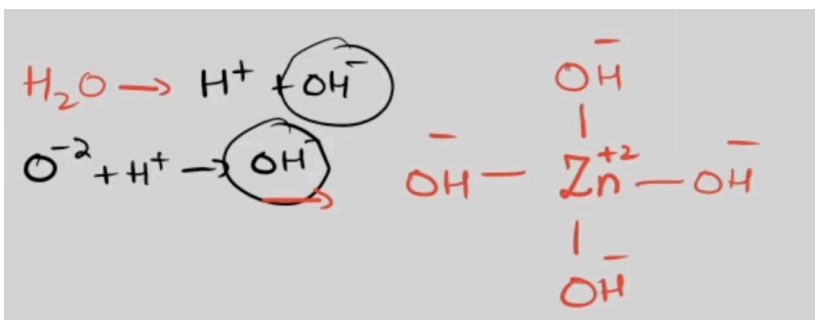
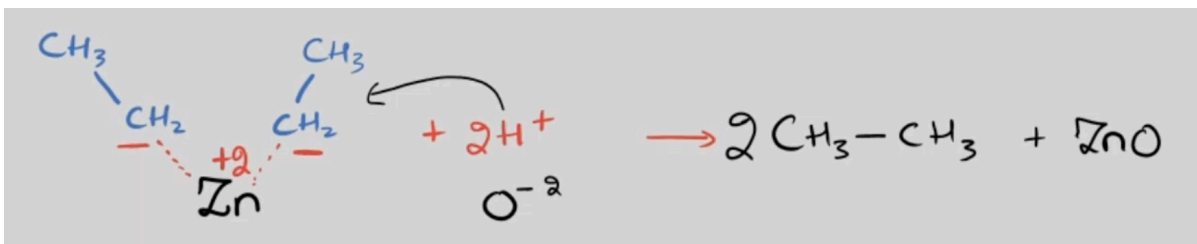

26.

Which solution has the lowest pH value?

- A 0.01 mol dm⁻³ butanoic acid
- B 0.01 mol dm⁻³ ethanoic acid
- C 0.01 mol dm⁻³ hydrochloric acid
- D 0.01 mol dm⁻³ sulfuric acid

Ans: D

Number of H⁺ ions produced by H₂SO₄ is higher; acid dissociation constant of HCl is lower.

27.

Sulfur dioxide is used as a preservative in wine making.

The following equations describe the reactions that occur when sulfur dioxide dissolves in water.

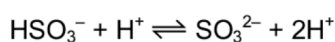
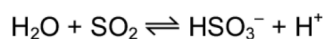

Which statement about **these two reactions** is correct?

- A HSO₃⁻ acts as a base.
- B SO₂ acts as an oxidising agent.
- C SO₃²⁻ acts as an acid.
- D SO₃²⁻ acts as a reducing agent.

Ans: A

- In both reactions, there is no change in oxidation state of oxygen and sulphur; thus reaction is not redox: rules out B and D.
- HSO_3^- is a conjugate base, which accepts a proton.

28.

In which reaction is the underlined substance acting as a base?

- A** $\text{HNO}_3 + \underline{\text{H}_2\text{SO}_4} \rightarrow \text{H}_2\text{NO}_3^+ + \text{HSO}_4^-$
- B** $\text{HSiO}_3^- + \underline{\text{HCN}} \rightarrow \text{CN}^- + \text{H}_2\text{O} + \text{SiO}_2$
- C** $\text{HNO}_2 + \underline{\text{HCO}_3^-} \rightarrow \text{H}_2\text{O} + \text{CO}_2 + \text{NO}_2^-$
- D** $\text{C}_6\text{H}_5\text{O}^- + \underline{\text{CH}_2\text{ClCO}_2\text{H}} \rightarrow \text{C}_6\text{H}_5\text{OH} + \text{CH}_2\text{ClCO}_2^-$

Ans: C

NOTE: HCO_3^- is a conjugate base!

conjugate base = substance formed by the removal of a proton from an acid.

HCO_3^- is formed by the removal of H^+ from H_2CO_3 .

29.

The equation for the reaction between silver chloride and aqueous ammonia is shown.

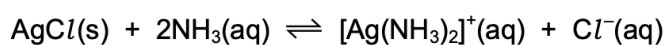

What are the units of K_c for this reaction?

- A** no units **B** $\text{mol}^{-1}\text{dm}^3$ **C** mol dm^{-3} **D** $\text{mol}^2\text{dm}^{-6}$

Ans: A

REMEMBER: solids are not included in K_c equation!!

30.

When an equimolar mixture of H_2 and I_2 react, the mole fraction of HI in the final mixture is x .

What is the equilibrium constant, K_p , for the reaction?

A $\frac{x^2}{(1-x)^2}$

B $\frac{x^2}{(1-2x)^2}$

C $\frac{4x^2}{(1-x)^2}$

D $\frac{4x^2}{(1-2x)^2}$

Ans: C

DOUBT!!

31.

0.200 mol of sulfur dioxide and 0.200 mol of oxygen are placed in a 1.00 dm^3 sealed container. The gases are allowed to react until equilibrium is reached.

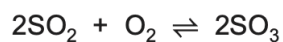

At equilibrium there is 0.100 mol of SO_3 in the container.

What is the value of K_c ?

A $0.150 \text{ mol dm}^{-3}$

B $0.800 \text{ mol dm}^{-3}$

C $1.25 \text{ mol}^{-1} \text{ dm}^3$

D $6.67 \text{ mol}^{-1} \text{ dm}^3$

Ans: D

32.

The diagram shows a gas syringe with a free-moving piston. The syringe contains gaseous hydrogen, gaseous iodine and gaseous hydrogen iodide at equilibrium.

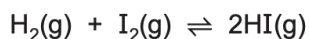
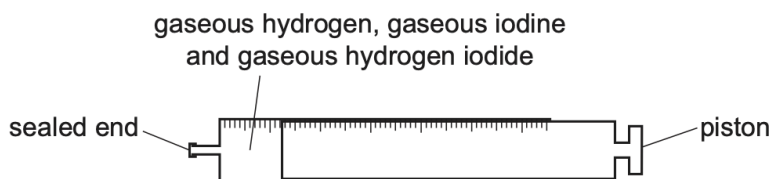

Three changes are listed.

- 1 increasing the total pressure by adding an inert gas and keeping the volume constant
- 2 increasing the pressure by adding more gaseous hydrogen iodide and keeping the volume constant
- 3 decreasing the volume by pushing the piston to the left

Which changes will result in an equilibrium position at which the rate of the forward reaction has increased?

- A** 2 only **B** 1 and 2 **C** 1 and 3 **D** 2 and 3

Ans: D

- In option 1, pressure has been increased, but volume is kept constant. Ideally, when pressure increases, volume decreases to increase the number of collisions. By keeping volume constant, there is no increase in number of collisions. Inert gas has no effect.
- In option 2, pressure is increased by adding more HI. This change will also shift equilibrium position to LHS, increasing the amount of I₂ and H₂, which increases the number of collisions.
- In option 3, decreasing volume increases pressure and increases number of collisions.

33.

NaOH(aq) is added to NH_4Cl (aq). The mixture is warmed.

The gas that is produced turns damp red litmus paper blue.

Which row is correct?

	behaviour of the ammonium ion in NH_4Cl	behaviour of the water present on the litmus paper
A	Brønsted–Lowry acid	Brønsted–Lowry base
B	Brønsted–Lowry acid	Brønsted–Lowry acid
C	Brønsted–Lowry base	Brønsted–Lowry acid
D	Brønsted–Lowry base	Brønsted–Lowry base

Ans: B

34.

Hydrogen and iodine react to form hydrogen iodide in an exothermic reaction. The equation is shown.

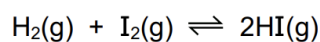

A 1 m^3 reaction vessel contains H_2 , I_2 and HI gases at equilibrium. The temperature is changed such that the total pressure in the 1 m^3 vessel doubles.

What is the effect on the value of K_p and on the position of equilibrium?

	effect on the value of K_p	effect on the position of equilibrium
A	decreases	moves left
B	increases	moves right
C	no change	moves left
D	no change	no change

Ans: A

35.

Diethylzinc, $(\text{C}_2\text{H}_5)_2\text{Zn}$, is added to $\text{NaOH}(\text{aq})$. Two reactions occur.

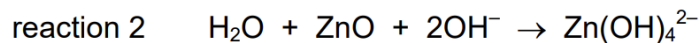
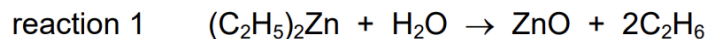

In these reactions, which compounds act as Brønsted–Lowry acids?

	reaction 1	reaction 2
A	$(\text{C}_2\text{H}_5)_2\text{Zn}$	H_2O
B	H_2O	H_2O
C	H_2O	ZnO
D	the reaction is not acid/base	ZnO

Ans: B

36.

A mixture of hydrogen gas and iodine gas is placed in a reaction vessel of volume V at temperature T .

The reaction $\text{H}_2 + \text{I}_2 \rightleftharpoons 2\text{HI}$ is allowed to come to equilibrium.

All substances remain in the gaseous state.

Argon gas is then pumped into the reaction vessel. The temperature in the vessel is maintained at T .

How are the rate of the forward reaction and the partial pressure of HI at equilibrium affected?

	rate of forward reaction	partial pressure of HI at equilibrium
A	increased	increased
B	increased	unaffected
C	unaffected	increased
D	unaffected	unaffected

Ans: D

- Argon is an inert gas – it does not react with any species in the system.
- Volume is constant, so adding argon increases the total pressure of the system but does not change the partial pressures of the reacting gases.
- Since the partial pressures remain unchanged, equilibrium position is not affected.

- Rate of forward reaction depends on the concentration (or partial pressures) of H₂ and I₂. Since these remain same, rate of forward reaction remains unchanged.

IMPORTANT: Adding an inert gas at constant volume does not affect the equilibrium concentrations or the reaction rate